

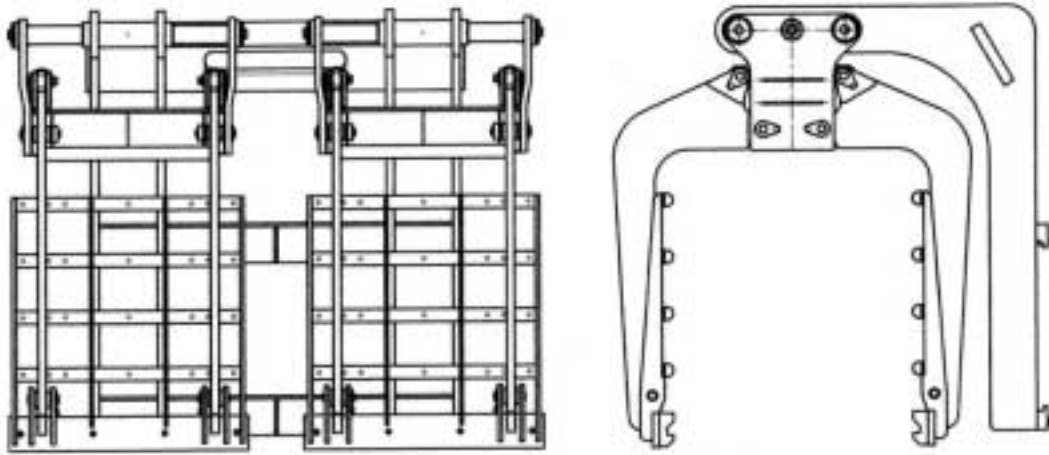

Product Data Sheet

F I E L D E N

E Series Twin Block Clamp



Model:	E30T
Capacity:	3000 kg at 915 mm load centre
Centre of Gravity:	900 mm
Weight:	1500 kg
Inside Height:	1075 mm
Opening Range:	1100 mm
Grippers:	900 mm (Gate leg shown)
Mounting:	Class 4A

Total sideshift and pack consolidation is via valve and top mounted slider frame.
Alternative specifications available
3 hydraulic functions

Fielden Handling Ltd

Walton Street
Sowerby Bridge
HX6 1AW

Phone: 01422 831548
Fax: 01422 834910
Email: sales@fielden.co.uk
Website: www.fielden.co.uk

Industrial Handling Equipment