

Twin Coil Handler

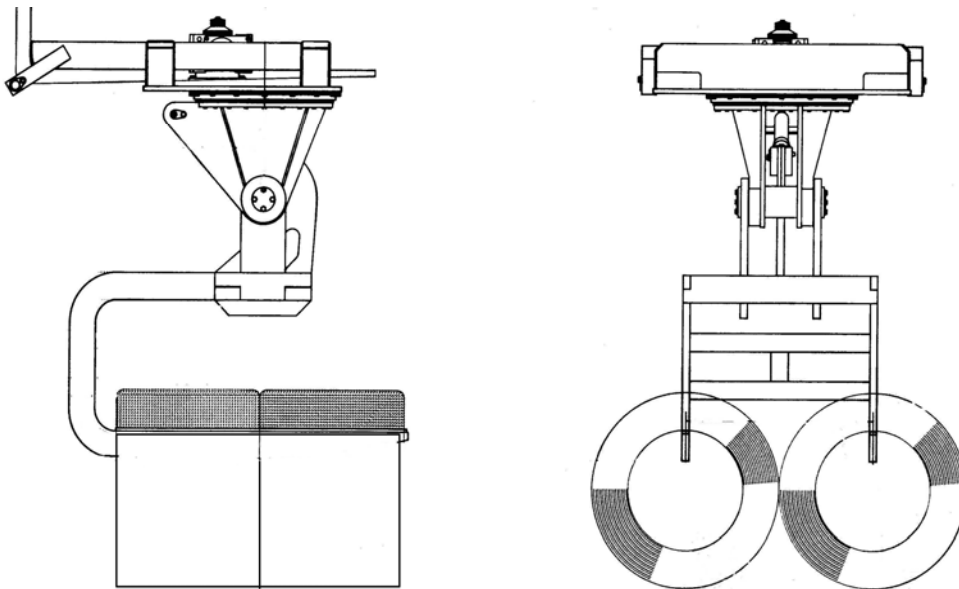

Model	Capacity at Load Centre	Centre of Gravity	Weight
TCH 05	5000 kg at 1650 mm	1350 mm	3400 kg
TCH 08	8000 kg at 1780 mm	1600 mm	3600 kg

Tines have shaped covers, tine length is to suit application.

360 degree rotation is standard.

2 hydraulic services required.

Above data is for fork mounting.

Specification can vary for different truck types and application, the details given above are indicative.

Consult Fielden for full technical specification.

Fielden Engineers Ltd

Walton Street
Sowerby Bridge
Halifax
HX6 1AW UK

Tel: +44 1422 831548
Fax: +44 1422 834910

email: sales@fielden.co.uk
www.fielden.co.uk

***Hydraulic Materials
Handling Equipment***